

# Rigging Equipment

## HASSELFORS

### Handy hints from Hasselfors

Our long experience has helped us to accumulate some practical hints and tips for making sailing safer and easier. We would like to pass on some of these handy hints, and hope that you will find them useful.

When the backstay has been fully tightened, mark the stay with a piece of tape at the top of the backstay tensioner. The tape marker will enable you to re-tension the stay accurately when ever necessary.

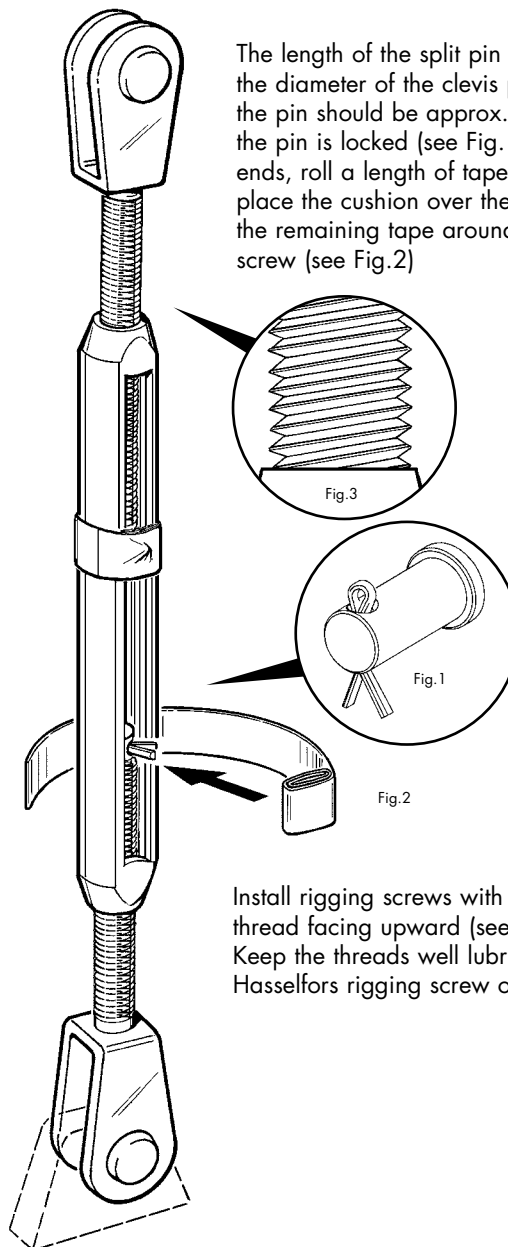
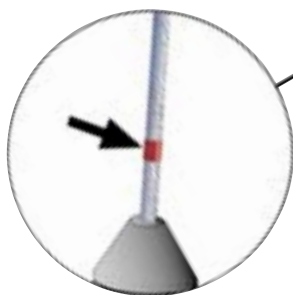

The length of the split pin should be 1.5 x the diameter of the clevis pin. The ends of the pin should be approx. 20° apart when the pin is locked (see Fig.1). To protect the ends, roll a length of tape into a cushion, place the cushion over the ends and wrap the remaining tape around the rigging screw (see Fig.2)

Install rigging screws with the right-hand thread facing upward (see Fig. 3). Keep the threads well lubricated with Hasselfors rigging screw oil.

### Rigging screw oil



Part No.	Size
HF-81012	100ml

All rigging screws (bronze or stainless steel) should be lubricated every year using Hasselfors special formula high-viscosity oil.